

Lathe Face-Plate Adapter

This adapter threads into your lathe's face plate so that you can add decorative carving details to a turned part, then return it to your lathe for further turning, without removing the face plate. The $\frac{5}{8}$ "-dia. post makes it easy to mount the adapter into the Veritas® Carver's Vise (or any other vise that takes a $\frac{5}{8}$ " shaft). The adapter is available in four thread sizes (1" \times 8 tpi, $\frac{3}{4}$ " \times 16 tpi, $1\frac{1}{4}$ " \times 8 tpi, and 33 mm \times 3.5 mm).

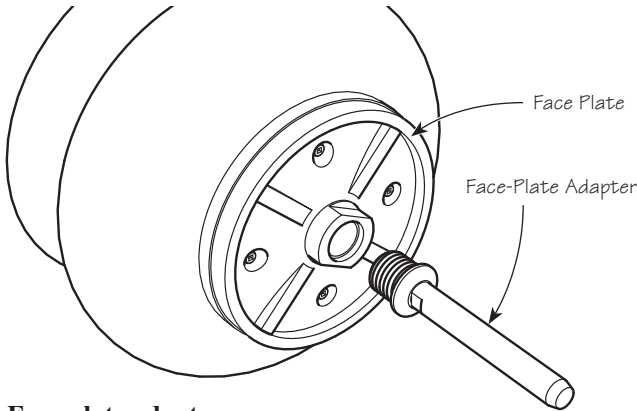

Figure 1: Face-plate adapter.

Installing the Adapter

1. Thread the adapter into your lathe's face plate and lock it in place with a $\frac{1}{2}$ " wrench.

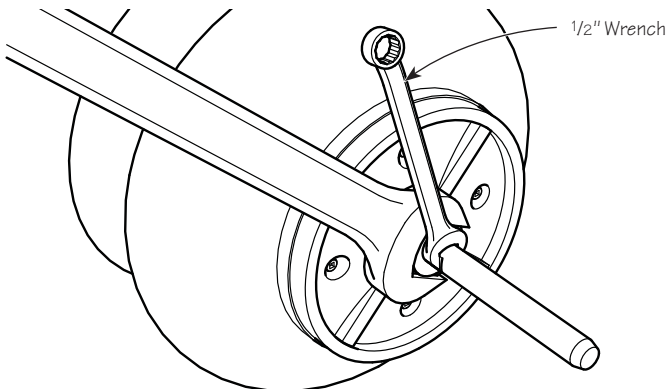

Figure 2: Threading the adapter into a face plate.

2. Loosen the clamp handle on the carver's vise and insert the adapter's post in the hole in the clamp shaft.

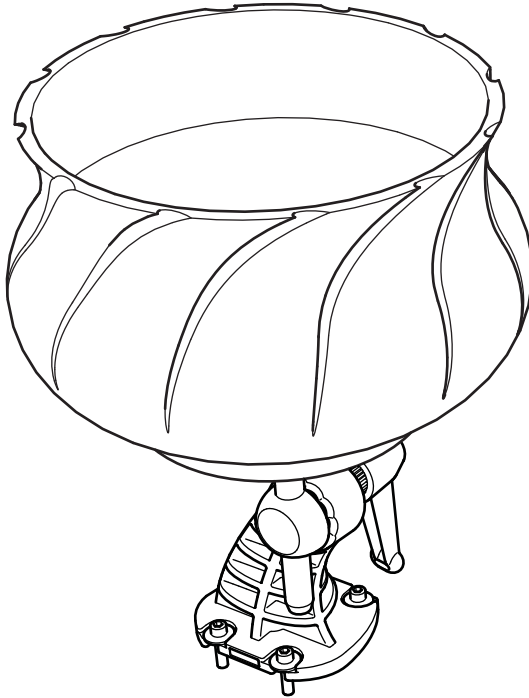

Figure 3: Inserting the adapter into the carver's vise.